

**THE UNITED STATES DISTRICT COURT  
FOR THE DISTRICT OF COLORADO**

Civil Action No.

CHRISTOPHER RECH,

Plaintiff,

v.

AMAZON.COM, INC,

Defendant.

---

**COMPLAINT & DEMAND FOR JURY TRIAL**

---

Plaintiff, **CHRISTOPHER RECH** (hereafter referred to as “Plaintiff”), by and through his undersigned counsel, **JOHNSON BECKER, PLLC** hereby submits the following Complaint and Demand for Jury Trial against Defendant **AMAZON.COM, INC.** (hereafter referred to as “Amazon,” and “Defendant”), alleges the following upon personal knowledge and belief, and investigation of counsel:

**NATURE OF THE CASE**

1. This is a product liability action seeking recovery for substantial personal injuries and damages suffered by Plaintiff, after Plaintiff was seriously injured by an “Instant Pot DUO 6-Quart Electric Pressure Cooker,” which specifically includes the Duo 60 V3 model (referred to hereafter as “pressure cooker(s)” or “Subject Pressure Cooker”) that is at issue in this case. The subject pressure cooker marketed, imported, distributed, and sold by Amazon and designed, manufactured, marketed, imported, distributed and/or sold by Instant Brands, Inc. (“Instant Brands”). Instant Brands is currently engaged bankruptcy proceedings in the United States Bankruptcy Court for the Southern District of Texas, and an automatic stay has been imposed. *See In re: Instant Brands*

*Acquisition Holdings, Inc., et. al.*, 4:2023-bk-90716 [Dkt. 1]. Instant Brands is, therefore, not subject to this Court’s jurisdiction under Colo. Stat. § 13-21-402 (2)

2. Defendant touts the “safety”<sup>1</sup> of its pressure cookers, and states that they cannot be opened while in use. Despite Defendant’s claims of “safety,” it designed, manufactured, marketed, imported, distributed, and sold, both directly and through third-party retailers, a product that suffers from serious and dangerous defects. Said defects cause significant risk of bodily harm and injury to its consumers.

3. Specifically, said defects manifest themselves when the lid of the pressure cooker is removable with built-up pressure, heat, and steam still inside the unit. When the lid is removed under such circumstances, the pressure trapped within the unit causes the scalding hot contents to be projected from the unit and into the surrounding area, including onto the unsuspecting consumers, their families, and other bystanders. The Plaintiff in this case sustained serious and substantial bodily injuries and damages when the lid of the pressure cooker was able to be rotated, opened, or removed while the pressure cooker retained pressure, causing him serious and substantial bodily injuries and damages.

4. Defendant knew or should have known of these defects, but has nevertheless put profit ahead of safety by continuing to sell its pressure cookers to consumers, failing to warn said consumers of the serious risks posed by the defects, and failing to recall the dangerously defective pressure cookers regardless of the risk of significant injuries to Plaintiff and consumers like him.

5. As a direct and proximate result of Defendant’s conduct, the Plaintiff in this case incurred significant and painful bodily injuries, medical expenses, lost wages, physical pain, mental anguish, and diminished enjoyment of life.

---

<sup>1</sup> See, e.g. Instant Pot Duo User Manual, pg. 21.

**PLAINTIFF CHRISTOPHER RECH**

6. Plaintiff is a resident and citizen of the City of Commerce City, County of Adams, State of Colorado. Plaintiff therefore is a resident and citizen of the State of Colorado for purposes of diversity pursuant to 28 U.S.C. § 1332.

7. On or about April 7, 2024, Plaintiff suffered serious and substantial burn injuries as the direct and proximate result of the pressure cooker's lid being able to be rotated and opened while the pressure cooker was still under pressure, during the normal, directed use of the pressure cooker, allowing its scalding hot contents to be forcefully ejected from the pressure cooker and onto Plaintiff. The incident occurred as a result of the failure of the pressure cookers supposed "safety mechanisms,"<sup>2</sup> which purport to keep the consumer safe while using the pressure cooker. In addition, the incident occurred as a result of Defendant's failure to redesign the pressure cooker, despite the existence of economical, safer alternative designs.

**DEFENDANT AMAZON.COM, INC.**

8. Defendant Amazon markets, imports, distributes and sells a variety of consumer products, including the subject pressure cooker in this case.

9. Defendant Amazon is, and was at the time of Plaintiff's injury, a corporation organized and existing under the laws of the state of Washington with its headquarters and principal place of business located in Washington. Amazon does business in all 50 states. Amazon is therefore deemed to be a resident and citizen of the State of Washington for purposes of diversity jurisdiction under 28 U.S.C. § 1332.

---

<sup>2</sup> See "10 Safety Mechanisms – DUO, DUO PLUS, LUX, NOVA PLUS AND VIVA," <https://www.instanthome.com/support/instant/resources>

10. At all times relevant, Amazon substantially participated in the marketing, import, distribution and sale of the subject pressure cooker, which caused Plaintiff's injuries and damages.

### **JURISDICTION AND VENUE**

11. This Court has subject matter jurisdiction over this case pursuant to diversity jurisdiction prescribed by 28 U.S.C. § 1332 because the matter in controversy exceeds the sum or value of \$75,000, exclusive of interest and costs, and there is complete diversity between the parties.

12. Venue is proper in this Court pursuant to 28 U.S.C. § 1391 all or a substantial part of the events or omissions giving rise to this claim occurred in this district.

13. Venue is also proper in this Court pursuant to 28 U.S.C. § 1391 because Defendant has sufficient minimum contacts with the State of Colorado and intentionally availed itself of the markets within Colorado through the promotion, sale, marketing, and distribution of its products.

14. Instant Brands is currently engaged bankruptcy proceedings in the United States Bankruptcy Court for the Southern District of Texas, and an automatic stay has been imposed. See *In re: Instant Brands Acquisition Holdings, Inc., et. al.*, 4:2023-bk-90716 [Dkt. 1]. Instant Brands is, therefore, not subject to this Court's jurisdiction under Colo. Stat. § 13-21-402 (2), and Amazon is deemed to be "the manufacturer of the product" under the same.

### **FACTUAL BACKGROUND**

15. Defendant is engaged in marketing, distributing, and selling the pressure cookers at issue in this litigation.

16. According to the User's Manual accompanying each individual unit sold, the pressure cookers possess a "Float Valve" which pops up and locks the lid of the cooker in place while the unit is pressurized, stating that "[a]s a safety feature, until the float valve drops down the lid is

locked and cannot be opened,”<sup>3</sup> misleading the consumer into believing that the pressure cookers are reasonably safe for their normal, intended use.

17. Because of the forgoing acts or omissions, the above-named Plaintiff used the pressure cooker with the reasonable expectation that it was properly designed and manufactured, free from defects of any kind, and that it was safe for its intended, foreseeable use of cooking.

18. Plaintiff used the pressure cooker for its intended purpose of preparing meals for himself and/or his family and did so in a manner that was reasonable and foreseeable by the Defendant.

19. However, the aforementioned pressure cooker was defectively and negligently designed in that it failed to properly function as to prevent the lid from being rotated, opened, or removed with normal force while the unit remained pressurized, during the ordinary, foreseeable and proper use of cooking food with the product; placing the Plaintiff, his family, and similar consumers in danger while using the pressure cookers.

20. The pressure cookers possess defects that make them unreasonably dangerous for their intended use by consumers because the lid can be rotated and opened while the unit remains pressurized.

21. Economic, safer alternative designs were available that could have prevented the Pressure Cooker’s lid from being rotated and opened while pressurized.

22. As a direct and proximate result of Defendant’s conduct, Plaintiff used an unreasonably dangerous pressure cooker, which resulted in significant and painful bodily injuries to Plaintiff.

23. Consequently, the Plaintiff in this case seeks compensatory damages resulting from the use of Defendant’s pressure cooker as described above, which has caused the Plaintiff to suffer from

---

<sup>3</sup> Instant Pot Duo User’s Manual, pg. 22.

serious bodily injuries, medical expenses, physical pain, mental anguish, diminished enjoyment of life, and other damages.

**CLAIMS FOR RELIEF**

**COUNT I**  
**STRICT LIABILITY**

24. Plaintiff incorporates by reference each preceding and succeeding paragraph as though set forth fully at length herein.

25. At the time of Plaintiff's injuries, the Pressure Cookers were defective and unreasonably dangerous for use by foreseeable consumers, including Plaintiff.

26. The Pressure Cookers were in the same or substantially similar condition as when they left the possession of Defendant.

27. Plaintiff did not misuse or materially alter his Pressure Cooker.

28. The Pressure Cookers did not perform as safely as an ordinary consumer would have expected them to perform when used in a reasonably foreseeable way.

29. Further, a reasonable person would conclude that the possibility and seriousness of harm outweighs the burden or cost of making the Pressure Cookers safe. Specifically:

- a. The Pressure Cookers sold and supplied by Defendant were defectively designed and placed into the stream of commerce in a defective and unreasonably dangerous condition for consumers;
- b. The seriousness of the potential burn injuries resulting from the product drastically outweighs any benefit that could be derived from its normal, intended use;
- c. Defendant failed to properly market, supply, and sell the Pressure Cookers, despite having extensive knowledge that the aforementioned injuries could and did occur;
- d. Defendant failed to warn and place adequate warnings and instructions on the Pressure Cookers;
- e. Defendant failed to adequately test the Pressure Cookers; and

- f. Defendant failed to market an economically feasible alternative design, despite the existence of the aforementioned economical, safer alternatives, that could have prevented the Plaintiff' injuries and damages.

30. Defendant's actions and omissions were the direct and proximate cause of the Plaintiff's injuries and damages.

**WHEREFORE**, Plaintiff demands judgment against Defendant for damages, together with interest, costs of suit, and all such other relief as the Court deems proper.

**COUNT II**  
**NEGLIGENCE**

31. Plaintiff incorporates by reference each preceding and succeeding paragraph as though set forth fully at length herein.

32. Defendant has a duty of reasonable care to market and sell non-defective Pressure Cookers that are reasonably safe for their intended uses by consumers, such as Plaintiff and her family.

33. Defendant failed to exercise ordinary care in the sale, warnings, advertising, promotion, sale and marketing of its Pressure Cookers in that Defendant knew or should have known that said Pressure Cookers created a high risk of unreasonable harm to the Plaintiff and consumers alike.

34. Defendant was negligent in the advertising, warning, marketing and sale of its Pressure Cookers in that, among other things, it:

- a. Failed to use due care in designing and manufacturing the Pressure Cookers to avoid the aforementioned risks to individuals;
- b. Placed an unsafe product into the stream of commerce;
- c. Aggressively over-promoted and marketed its Pressure Cookers through television, social media, and other advertising outlets; and
- d. Were otherwise careless or negligent.

35. Despite the fact that Defendant knew or should have known that consumers were able to remove the lid while the pressure cookers were still pressurized, Defendant continued to market

its pressure cookers to the general public (and continues to do so).

**WHEREFORE**, Plaintiff demands judgment against Defendant for damages, together with interest, costs of suit, attorneys' fees, and all such other relief as the Court deems proper.

**DEMAND FOR JURY TRIAL**

Plaintiff demands that all issues of fact of this case be tried to a properly impaneled jury to the extent permitted under the law.

**PRAYER FOR RELIEF**

**WHEREFORE**, Plaintiff demands judgment against the Defendant for damages, including exemplary damages if applicable, to which he is entitled by law, as well as all costs of this action, interest and attorneys' fees, to the full extent of the law, whether arising under the common law and/or statutory law, including:

- a. judgment for Plaintiff and against Defendant;
- b. damages to compensate Plaintiff for her injuries, economic losses and pain and suffering sustained as a result of the use of the Defendant's pressure cooker;
- c. pre and post judgment interest at the lawful rate;
- d. a trial by jury on all issues of the case ;and
- e. for any other relief as this Court may deem equitable and just, or that may be available under the law of another forum to the extent the law of another forum is applied, including but not limited to all reliefs prayed for in this Complaint and in the foregoing Prayer for Relief.

Respectfully Submitted,

Dated: March 20, 2026

**JOHNSON BECKER, PLLC**

/s/ Adam J. Kress, Esq.  
Adam J. Kress, Esq. (MN #0397289)  
444 Cedar Street, Suite 1800  
St. Paul, MN 55101  
(612) 436-1800 / (612) 436-1801 (f)  
[akress@johnsonbecker.com](mailto:akress@johnsonbecker.com)

*Attorneys for Plaintiff*

*get started*

INSTANT POT® DUO®  
**MULTI-COOKER**  
USER MANUAL

Instant Pot®

# Welcome

to your new Instant Pot® Duo® Multi-Cooker!

This Instant Pot Duo Multi-Cooker can help you cook delicious meals more easily and in less time. We hope you fall in love with Instant Pot cooking and enjoy it in your kitchen for years to come.

Get started with your new Instant Pot!



## **⚠️ WARNING**

Before using your new appliance, read all instructions, including the Important Safeguards. **Failure to follow the safeguards and instructions may result in personal injury and/or property damage.**

## CONTENTS

Important safeguards	2
What's in the box	7
Using your Instant Pot Duo	9
Initial setup	16
Pressure cook	19
Sauté	25
Slow cook	27
Yogurt making	28
Keep warm	30
Cleaning	31
Troubleshooting	33
Error codes	35
Replacement parts	36
Learn more	38
Warranty	39
Notes	41



# IMPORTANT SAFEGUARDS

## ⚠ WARNING

**Failure to follow safety instructions may result in personal injury and/or property damage and may void your warranty.**

## READ ALL INSTRUCTIONS

Before using your new appliance, please read all instructions, including the Safety Information below. Keep this manual for reference.

### Placement

- **DO** place the appliance on a countertop only. Always operate the appliance on a stable, non-combustible, level surface.
- **DO** make sure all parts are dry and free of food debris before placing the inner cooking pot on the cooker base.
- **DO NOT** place the appliance or power cord on or close to a gas or electric stovetop or oven. **NEVER** use the appliance on your stove.
- **DO NOT** use the appliance near water, an external heat source or flame.
- **DO NOT** use outdoors. Keep out of direct sunlight.
- **DO NOT** place on anything that may block the vents on the bottom of the appliance.

### General Use

The removable inner cooking pot is extremely hot during use and can be extremely heavy when full of ingredients.

- **DO** use oven mitts when handling the inner cooking pot and removing accessories.
- **DO** place hot accessories on a heat-resistant surface or cooking plate.
- **DO** use care when lifting the cooking pot from the cooker base to avoid burn injury.
- **DO** use extreme caution when the cooking pot contains hot food, hot oil or other hot liquids.
- **DO** use only the Instant Pot lid that came with this cooker base. Using any other pressure cooker lids may cause personal injury and/or property damage.

**⚠ WARNING**

**Failure to follow safety instructions may result in personal injury and/or property damage and may void your warranty.**

- **DO NOT** use the appliance without the removable inner cooking pot installed.
- **DO NOT** touch the appliance's hot surfaces, or any accessories during or immediately after cooking because they will be hot. Only use the appliance's side handles for carrying or moving.
- **DO NOT** use this appliance for deep frying or pressure frying with oil.
- **DO NOT** move the appliance while it is in use and use extreme caution when disposing of hot grease.
- **DO NOT** allow children or persons with reduced physical, sensory or mental capabilities to operate this appliance. Close supervision is necessary when any appliance is used by or near children and persons with reduced physical, sensory or mental capabilities. Children should not play with this appliance.
- **DO NOT** use the appliance for anything other than household use. It is not intended for commercial use.
- **DO NOT** leave the appliance unattended while in use.

### Pressure Cooking

This appliance cooks under pressure. Allow the appliance to depressurize naturally or release all excess pressure before opening.

**Failure to follow these instructions may result in burns, personal injury and/or property damage.**

- **DO** make sure the appliance is properly closed before operating.
- **DO** check that the steam release valve is installed properly.
- **DO** use the pressure cooking lid when pressure cooking.
- **DO** turn the appliance off if steam escapes from the steam release valve and/or float valve in a steady stream for longer than 3 minutes. If steam escapes from the sides of the lid, turn the appliance off. Once steam stops, pressure is released and the cooker has cooled, carefully make sure the sealing ring is properly installed.
- **DO** ensure the sealing ring is in good condition and installed properly.
- **DO** check the steam release valve, steam release pipe, anti-block shield and float valve for clogging before use.
- **DO NOT** remove the pressure cooking lid with unprotected hands.

**⚠ WARNING**

**Failure to follow safety instructions may result in personal injury and/or property damage and may void your warranty.**

- **DO NOT** attempt to force the lid off the Instant Pot cooker base.
- **DO NOT** move the appliance when it is pressurized.
- **DO NOT** cover or obstruct the steam release valve and/or float valve with cloth or other objects.
- **DO NOT** attempt to open the appliance until it has depressurized, and all internal pressure has been released. Attempting to open the appliance while it is still pressurized may lead to sudden release of hot contents and may cause burns, personal injury and/or property damage.
- **DO NOT** place your face, hands or exposed skin over the steam release valve or float valve when the appliance is in operation or has residual pressure, and do not lean over the appliance when removing the lid.

### Overfill During Pressure Cooking

Overfilling may cause a risk of clogging the steam release pipe and valve, developing excess pressure.

- **DO NOT** fill the inner cooking pot over the line labeled 'PC MAX' or 'Max PC Fill'.
- **DO NOT** fill the inner cooking pot over the line labeled '1/2' when cooking foods that expand during cooking such as rice, dried beans or dried vegetables.
- **DO** be aware that certain foods, such as applesauce, cranberries, pearl barley, oatmeal or other cereals, split peas, noodles, macaroni, rhubarb, or spaghetti can foam, froth and sputter, and clog the steam release pipe and valve. **DO NOT** fill the inner cooking pot over the line labeled '1/2' when cooking these foods.
- **DO NOT** place oversized foods into the inner cooking pot as they may cause risk of fire, personal injury and/or property damage.

### Accessories

- **DO** use only accessories or attachments authorized by Instant Pot Brands. The use of parts, accessories or attachments not recommended by the manufacturer may cause a risk of electric shock or other personal injury, fire and/or property damage.

**⚠ WARNING**

**Failure to follow safety instructions may result in personal injury and/or property damage and may void your warranty.**

- **DO** use only an authorized Instant Pot inner cooking pot to reduce the risk of pressure leakage.
- **DO** only replace the sealing ring with an authorized Instant Pot sealing ring to prevent personal injury, property damage, and/or damage to the appliance.
- **DO NOT** use the included accessories in a microwave, toaster oven, convection or conventional oven, on a ceramic, electric or gas cooktop, or with an outdoor grill.

**Care and Storage**

- **DO** let the appliance cool to room temperature before cleaning or storage.
- **DO NOT** store any materials, other than the inner cooking pot, in the cooker base when not in use.
- **DO NOT** place any combustible materials in the cooker base, such as paper, cardboard, plastic, Styrofoam or wood.

**Power Cord**

A short power-supply cord is used to reduce the hazards resulting from grabbing, entanglement or tripping. **WARNING:** Hot spilled food can cause serious burns.

- **DO** keep appliance and power cord away from children.
- **DO** disconnect the power cord from the electrical outlet when not using the appliance and before cleaning.
- **DO NOT** let the power cord hang over edges of tables or counters.
- **DO NOT** let the power cord touch hot surfaces or open flame, including a stovetop.
- **DO NOT** use below-counter power outlets.
- **DO NOT** use with extension cords, power converters or adapters, timer switches or separate remote-control systems.

This appliance has a polarized plug and one blade is wider than the other. To reduce the risk of electric shock:

- **DO** plug this appliance into a polarized outlet one way.
- **DO** contact a qualified electrician if the plug does not fit in the outlet.
- **DO NOT** attempt to modify the plug. If the plug does not fit full into the outlet, reverse the plug.

**⚠ WARNING****Electrical Warning**

The cooker base contains electrical components that are an electrical shock hazard. **Failure to follow these instructions may result in electric shock and/or death.**

**To protect against electrical shock:**

- To disconnect, select **Cancel**, then remove plug from power source. Always unplug when not in use, as well as before adding or removing parts or accessories, and before cleaning. To unplug, grasp the plug and pull from the outlet. **NEVER** pull from the power cord.
- **DO** regularly inspect the appliance and power cord for any signs of damage or fraying.
- **DO NOT** operate the appliance if the power cord or plug is damaged, or after the appliance malfunctions or is dropped or damaged in any manner. For assistance, contact Consumer Care by email at **support@instantpot.com**.
- **DO NOT** attempt to repair, replace or modify components of the appliance, as this may cause electric shock or other personal injury, fire and/or property damage, and will void the warranty. For assistance, contact Consumer Care by email at **support@instantpot.com**.
- **DO NOT** tamper with any of the safety mechanisms, as this may result in personal injury and/or property damage.
- **DO NOT** put liquid or food of any kind into cooker base without the inner cooking pot.
- **DO NOT** immerse the power cord, plug or the appliance in water or other liquid.
- **DO NOT** clean the appliance by rinsing it under a faucet.
- **DO NOT** use the appliance in electrical systems other than 120 V ~ 60 Hz for North America.

**SAVE THESE INSTRUCTIONS****⚠ WARNING**

**Failure to follow safety instructions may result in personal injury and/or property damage and may void your warranty.**

## WHAT'S IN THE BOX

### Lid

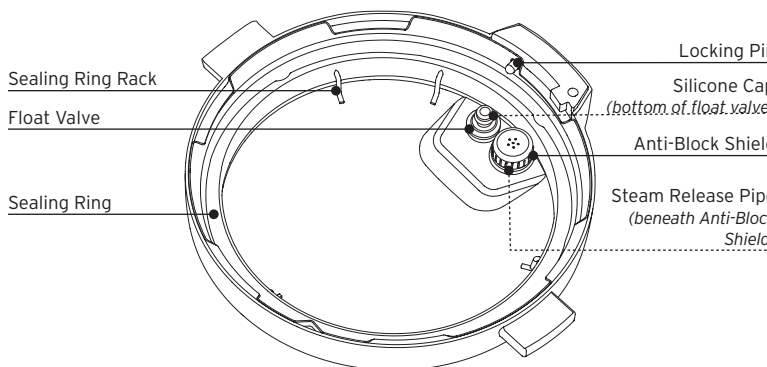
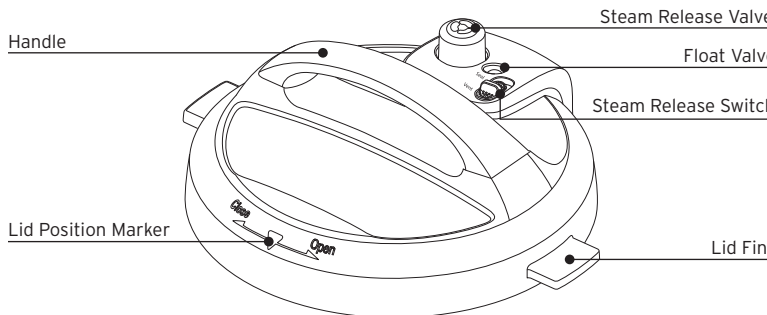

Stand the lid up in the base handles to keep it off your countertop. Insert the left or right lid fin into corresponding slot in the cooker base handles to stand it up and save some space.

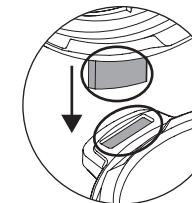

*Illustrations are for reference only and may differ from the actual product.*

## Stainless Steel Cooking Pot

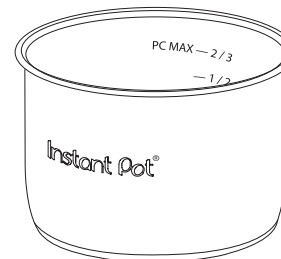

## Cooker Base

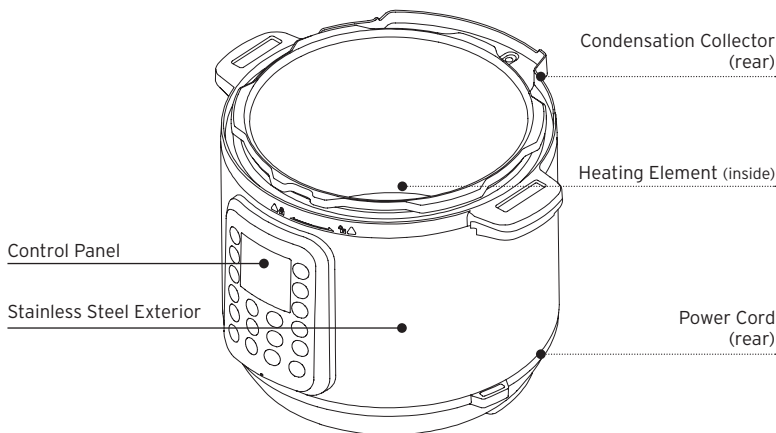

## Remember to recycle!

We designed this packaging with sustainability in mind. Please recycle everything that can be recycled where you live.

## USING YOUR INSTANT POT DUO

### Control panel

We've designed the control panel to be simple to use and easy to read.

#### 3QT Model

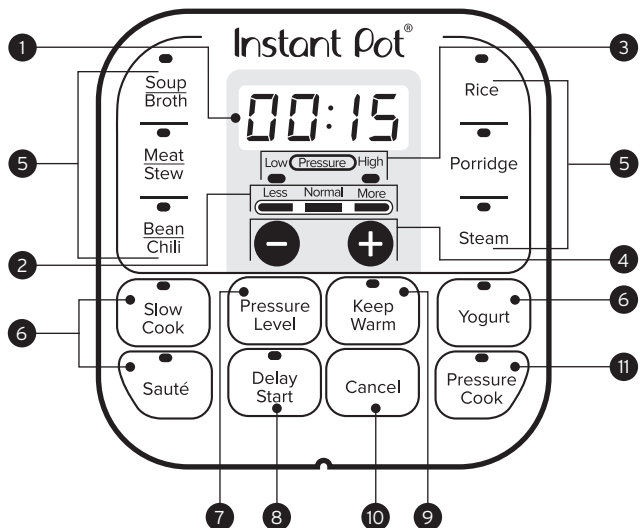

1. Cooking Settings Display

- Cooking time
- Messages

2. Cooking Time Indicators

- Set for each program

3. Pressure indicators

- Low or High when lit

4. Decrease/Increase

- Adjust time and temperature

5. Pressure Cooking Smart Programs

- Active when lit

6. Non-Pressure Cooking

- Smart Programs
- Active when lit

7. Pressure Level

- Press to change

8. Delay Start

- Active when lit
- Press to change

9. Keep Warm

- Active when lit
- Press to change

10. Cancel

- Press to end cooking

11. Pressure Cook

- Active when lit
- Press to change

## 6QT &amp; 8QT Model

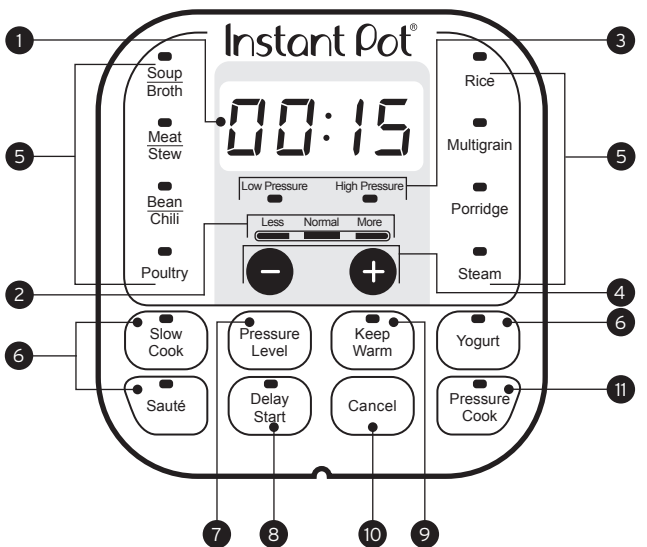

1. Cooking Settings Display
  - Cooking time
  - Messages
2. Cooking Time Indicators
  - Set for each program
3. Pressure indicators
  - Low or High when lit
4. Decrease/Increase
  - Adjust time and temperature
5. Pressure Cooking Smart Programs
  - Active when lit
6. Non-Pressure Cooking Smart Programs
  - Active when lit
7. Pressure Level
  - Press to change
8. Delay Start
  - Active when lit
  - Press to change
9. Keep Warm
  - Active when lit
  - Press to change
10. Cancel
  - Press to end cooking
11. Pressure Cook
  - Active when lit
  - Press to change

## Status messages

The control panel shows information you need to know when using your Instant Pot Duo.

OFF	Standby mode
On	Preheat mode
Lid	Lid not properly secured or missing
05:20	Time <ul style="list-style-type: none"><li>• Smart Program: cooking time remaining</li><li>• Delay Start: time until Smart Program starts</li><li>• Keep Warm: time food has been warming</li></ul>
Auto	Rice Smart Program is running
boil	Yogurt Smart Program is in pasteurizing cycle
Hot	Sauté Smart Program is ready to add food
End	Smart Program ended (Keep Warm is off)
Food burn	Overheating: see Troubleshooting on pages 33-34
E	Error: see Troubleshooting on pages 33-34

## Using the lid

You'll use the pressure cooking lid for all cooking programs with your Instant Pot Duo. Always use the pressure cooking lid that came with this Instant Pot Duo cooker base.

### Open the Lid

1. Turn the **lid handle** to align the arrow symbol ▼ on the lid with the unlock symbol 🔒▲ on the **cooker base**.

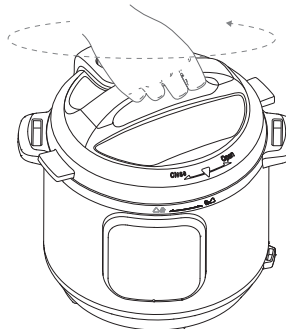



2. Lift the lid up and off the **cooker base**.

*You can insert the handle into the cooking base vertically for easy storage.*

## Close the Lid

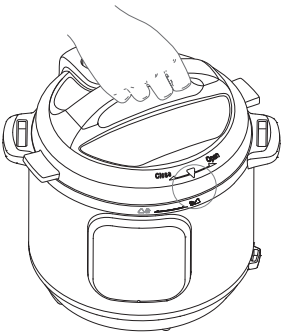
1. Align the arrow symbol ▼ on the lid with the unlock symbol ▲ on the cooker base and lower the lid onto the track.



2. Turn the lid until the arrow symbol ▼ on the lid aligns with the lock symbol ▲ on the cooker base.

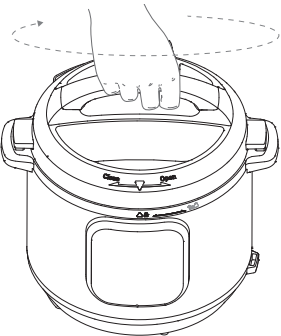

## Turning the sound On/Off

### Turn sound on

When in Standby mode, press and hold + button until display shows S On.

### Turn sound off

When in Standby mode, press and hold - button until display shows SOFF.

*Audible safety alerts (beeps) cannot be turned off.*

## Delay the start of cooking

You can set a Delay Start timer for a minimum of 10 minutes or a maximum of 24 hours.

1. Select a Smart Program, adjust the settings as you want, then press **Delay Start**.  
*Once Delay Start has been selected, there is no way to return to the cooking settings. To adjust Smart Program settings, press Cancel and enter new selections.*
2. When the hours field flashes, use the - / + buttons to adjust the delay time hours.
3. Press **Delay Start** again to toggle to the minutes field and adjust the delay time minutes.
4. Delay Start begins automatically and the timer counts down.
5. When Delay Start ends, the Smart Program begins, and the display indicates **On**.

*Delay Start is not available with the Sauté or Yogurt Smart Programs.*

## Reset Smart Programs to original settings

### Reset Individual Smart Programs

- With the cooker in Standby mode, press and hold one Smart Program button until the cooker returns to Standby and shows **OFF**.

*The Smart Program's pressure level, cooking time and temperature are restored to the factory default setting.*

### Reset All Smart Programs

- With the cooker in Standby mode, press and hold **Cancel** until the cooker beeps.

*All Smart Program pressure levels, cooking times and temperatures are restored to the factory default setting.*

## Change the Control Panel display language

You can select the language shown on the Control Panel display.

*Choose from: English or French.*

1. When the display shows **OFF**, press **Delay Start** and **Cancel** for over 3 seconds. The display shows **En Fr**, with the current language blinking.
2. Press **Delay Start** or **Cancel** to select a new language. The selected language blinks.
3. Within 10 seconds, press the **Delay Start** and **Cancel** to confirm your selection.

## Change the language for Control Panel buttons

Models sold in Canada include a French language overlay. To affix the overlay:

1. Make sure the Control Panel is clean and dry.
2. Peel off the paper backing from the overlay.
3. Attach the overlay to the Control Panel, using these guidelines:
  - Align the overlay shape with the Control Panel shape.
  - Use the Time/Temp and setting display cutouts as a guide for placing the overlay.
  - Cover the English text with the French text exactly.
  - Make sure all LED indicator lights are visible with the overlay attached.
  - Place the overlay carefully, since the adhesive is permanent.

## INITIAL SETUP

### Clean before use

1. Hand wash the cooking pot with hot water and dish soap. Rinse and use a soft cloth to dry the outside. Or you can wash the cooking pot in the dishwasher.
2. Wipe the heating element inside the cooker base with a soft cloth to ensure there are no stray packaging particles.

### Setting up the condensation collector

The condensation collector sits at the back of the cooker base and accumulates overflow moisture from the condensation rim. It should be installed before cooking, then emptied and rinsed out after each use.

### Remove the condensation collector

- Pull the **condensation collector** away from the **cooker base**; do not pull down.

*Note the tabs on the cooker base and the grooves on the condensation collector.*

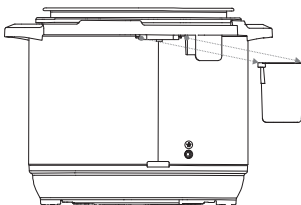

### Install the condensation collector

- Align the grooves on the **condensation collector** with the tabs on the back of the **cooker base** and slide the **condensation collector** into place.

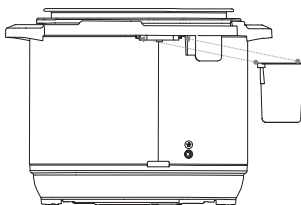

## Using the Sealing Ring

When the pressure cooking lid is closed, the sealing ring installed on the underside of the lid creates an air-tight seal between the lid and the cooker base.

- The sealing ring must be installed before using the cooker and should be cleaned after each use.
- Install 1 sealing ring at a time; use one for sweet dishes and one for savory.
- Sealing rings stretch over time with normal use. To keep your product safe, replace the sealing ring every 12 to 18 months. Replace sooner if you notice stretching, deformation, or damage.

## Install the Sealing Ring

1. Place the **sealing ring** over the **sealing ring rack** and press it into place. Press down firmly to ensure there is no puckering.
2. The **sealing ring** should be snug and should not fall out when the lid is turned over.

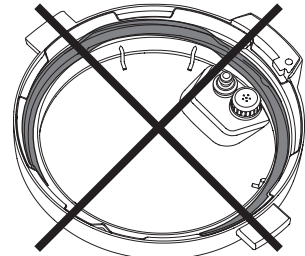
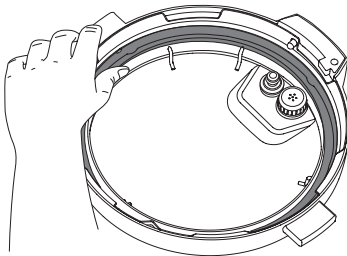

## Remove the Sealing Ring

1. Grip the edge of the **sealing ring** and pull it out from behind the **sealing ring rack**.
2. Inspect the **rack** to ensure it is secured, centered, and an even height all the way around the lid. If the **sealing ring rack** is deformed, **do not** try to repair it.

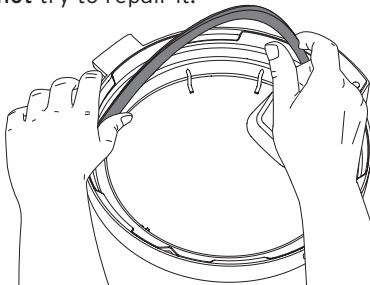

## Connect to power

When you're ready to use your Instant Pot, plug the power cord into an electrical outlet. When you're done cooking and whenever you're cleaning the multi-cooker, unplug the cord from the outlet.

## Test run

Setting up your new Instant Pot Duo for a test run is a great way to familiarize yourself with how the unit works before you actually cook a meal.

### To perform a test run:

1. Follow the instructions for pressure cooking on page 19 using the Steam Smart Program.
2. Add water (but no food) to the **cooking pot** as shown in 'Using liquid to create steam' on page 20.
3. Set the cooking time to 5 minutes.
4. After the cooking session is done, discard any remaining water.
5. Wash and dry the **cooking pot**.

*Now you're ready to cook a meal in your Instant Pot Duo!*

## PRESSURE COOK

Pressure cooking uses pressurized steam to quickly and evenly cook foods.

### How to pressure cook

#### Prep

Cut, chop, season or marinate your ingredients according to your recipe.

#### Preheat

1. Place the **cooking pot** into the **cooker base**.
2. Add ingredients to the **cooking pot**.
3. Place the **lid** on top of the **cooker base** and lock the **lid**.  
*See "How to lock the lid" on page 20.*
4. Select a Smart Program for cooking by pressing the button on the **control panel**.  
*See "Pressure Cooking Smart Programs" on page 21.*
5. Press the Smart Program again to toggle between time options: **Less, Normal** or **More**.
6. If you want to increase or decrease the cooking time exactly, press **+** or **-**.
7. Press **Pressure Level** to toggle between pressure options: **High** or **Low**.
8. Keep Warm setting is ON by default. Press **Keep Warm** again to turn it off.
9. After 10 seconds, the display shows **On** and the Instant Pot Duo is building pressure.

*It can take up to 30 minutes to reach the pressure setting for cooking. Frozen foods increase the preheating time.*

*The pressure level and time you choose will become the new settings the next time you use that Smart Program.*

## Cook

1. When the pressure is ready, your Instant Pot Duo will beep once and start cooking.
2. The cooking timer starts counting down.
3. When the timer reaches 00:00, the cooker will beep 5 times and cooking will stop.

You can press **Cancel** to stop a Smart Program at any time.

## Release steam

Choose the steam release method that works for your recipe.

See "How to release steam" on page 21 for full details.

## Using liquid to create steam

Pressure cooking requires liquid in the cooking pot to produce the steam needed. Depending on the size of your Instant Pot Duo, here are the minimum amounts you'll need:



Instant Pot Size	Minimum Liquid for Pressure Cooking*
3 Quarts / 2.8 Litres	1 cup (8 oz / 250 mL)
6 Quarts / 5.7 Litres	1 1/2 cups (12 oz / 375 mL)
8 Quarts / 7.6 Litres	2 cups (16 oz / 500 mL)

\*Unless otherwise specified in recipe.

Pressure cooking liquids should be water-based, such as broth, stock, soup or juice. If using canned, condensed, or cream-based soup, add water as directed above.

## How to lock the lid

For pressure cooking, the lid must be securely locked into place to prevent steam from escaping. When you place the lid on the cooker base:

1. Line up the arrow symbol ▼ on lid with the unlock symbol ▲ on the cooker base.
2. Turn lid clockwise until the arrow symbol ▼ on lid lines up with the lock symbol ▲ on cooker base.

## How to release steam

Instant Pot Duo can release steam in 2 different ways. Use the one that best fits the type of food you're cooking.

### Natural steam release

Releases steam gradually over time (up to 40 minutes or more) after cooking stops.

Use for: Foods that can simmer, like stews, chili, pasta, oatmeal, beans and grains.

1. After cooking, leave **steam release switch** in **Seal** position until all pressure is released.
2. **Float valve** drops into **lid** when all steam is released.
3. After steam release, turn **lid** counterclockwise and remove the **lid**.

### Quick steam release

Quickly releases steam after you press the steam release switch.

Use for: Foods that tend to overcook, like vegetables and seafood.

1. After cooking, set **steam release switch** to **Vent** position and wait for all pressure to release.
2. **Float valve** drops into **lid** when all steam is released.
3. After steam release, turn **lid** counterclockwise and remove the **lid**.

### **⚠ CAUTION**

This appliance uses pressure to cook. Allow the appliance to release all excess pressure and steam before opening the lid. Opening the lid before pressure is released may result in burns, personal injury and/or property damage. Read more in the Safety, Maintenance and Warranty sections.

## Pressure Cooking Smart Programs

These Smart Programs are designed to pressure cook specific types of food. You can adjust the settings as your recipe directs.

### Soup/Broth

<b>Pressure</b>	Low / High		
<b>Setting</b>	Less	Normal	More
<b>Cooking Time</b>	20 minutes (00:20)	30 minutes (00:30)	4 hours (04:00)
<b>Best for</b>	Soup without meat	Soup with meat	Bone broth / High fat content

#### **Tip**

*The soup/broth remains clear due to a lack of boiling motion.*

*Use **Natural Release** for soups with a higher starch content.*

### Meat/Stew

<b>Pressure</b>	Low / High		
<b>Setting</b>	Less	Normal	More
<b>Cooking Time</b>	20 minutes (00:20)	35 minutes (00:35)	45 minutes (00:45)
<b>Best for</b>	Softer texture	Very soft texture	Fall-off-the-bone texture

#### **Tip**

*Allow meat to rest for 5-30 minutes after cooking to retain juices.*

## Beans/Chili

<b>Pressure</b>	Low / High		
<b>Setting</b>	Less	Normal	More
<b>Cooking Time</b>	25 minutes (00:25)	30 minutes (00:30)	40 minutes (00:40)
<b>Best for</b>	Firmer texture	Soft Texture	Very soft texture

### Tips

Choose setting based on desired bean texture or adjust the cook time manually. When cooking beans or legumes, always use **Natural Release** method. Make sure dry beans are completely submerged in water.

## Poultry

<b>Pressure</b>	Low / High		
<b>Setting</b>	Less	Normal	More
<b>Cooking Time</b>	5 minutes (00:05)	15 minutes (00:15)	30 minutes (00:30)
<b>Best for</b>	Softer texture	Very soft texture	Fall-off-the-bone texture

### Tip

Allow meat to rest for 5-30 minutes depending on size. It will retain cooking juices for tender, succulent meat.

## Rice

<b>Pressure</b>	Low / High		
<b>Setting</b>	Less	Normal	More
<b>Cooking Time (Auto)</b>	8 minutes (00:08)	12 minutes (00:12)	15 minutes (00:15)
<b>Best for</b>	Al-dente / White Rice	Normal texture / White Rice	Softer texture / White Rice

### Tips

The Instant Pot Duo automatically adjusts cooking time depending on volume of rice; display will show **Auto**. Use a 10-minute timed steam release for fluffy rice.

## Multigrain

<b>Pressure</b>	Low / High		
<b>Setting</b>	Less	Normal	More
<b>Cooking Time</b>	20 minutes (00:20)	40 minutes (00:40)	1 hour +45 minutes soaking (01:45)
<b>Best for</b>	Al dente / Brown rice	Brown or wild rice	Tough grains or a mixture of grains and beans

### Tip

The **More** setting will add an additional 45 minutes for soaking grains/beans with 60 minutes of pressure cooking.

## Porridge

<b>Pressure</b>	Low / High		
<b>Setting</b>	Less	Normal	More
<b>Cooking Time</b>	5 minutes (00:05)	20 minutes (00:20)	30 minutes (00:30)
<b>Best for</b>	Oatmeal: steel cut or rolled	Pudding, porridge, or congee	Porridge or congee with a mixture of various grains

### Tips

Adjust cooking time as recipe directs.

Use **Natural Steam Release** when cooking foods that expand.

## Steam

<b>Pressure</b>	Low / High		
<b>Setting</b>	Less	Normal	More
<b>Cooking Time</b>	3 minutes (00:03)	10 minutes (00:10)	15 minutes (00:15)
<b>Best for</b>	Vegetables	Fish and seafood	Meat

### Tips

Use the provided steam rack to elevate food above cooking liquid.

Use **Quick Steam Release** to avoid overcooking food.

## SAUTÉ

Use Sauté in place of a frying or saucepan. Sautéing can deepen the flavors of your food, or can simmer, thicken or reduce sauces.

Choose from these settings in the Sauté Smart Program:

<b>Setting</b>	More 392°F / 200°C	Normal 302°F / 150°C	Less 221°F / 105°C
<b>Cooking time</b>	30 minutes (00:30)	30 minutes (00:30)	30 minutes (00:30)
<b>Best for</b>	Simmering, thickening, and reducing liquids	Pan-searing or sautéing	Stir-frying or browning meat

### How to sauté

#### Prep

Cut, chop, season or marinate your ingredients according to your recipe.

#### Preheat

1. Place the **cooking pot** into the **cooker base**.
2. Press **Sauté**.
3. Cycle through temperature presets to select **Less**, **Normal**, or **More**.
4. Press **- / +** to adjust cooking time.
5. After 10 seconds, the cooker beeps 3 times and the Display shows **ON**.

#### Cook

1. When display shows **Hot**, add ingredients. Only use high-heat oils to Sauté in the pressure cooker.
2. When timer ends, the cooker beeps 10 times and the display shows **End**.
3. Press **Cancel** if you want to finish cooking before timer runs out.

## Deglazing

Deglazing is the process of adding a liquid to a hot pan, releasing all of the delicious, caramelized pieces stuck to the bottom.

1. Remove food from **cooking pot**.
2. Add water, broth, or wine according to your recipe.
3. Use wooden spoon or silicone spatula to loosen food stuck to bottom of the **cooking pot**.

## Sautéing before Pressure or Slow Cooking

Quite often, you'll want to sauté foods to brown them before further cooking them.

1. Sauté ingredients.
2. Press **Cancel**.

*You can deglaze the cooking pot now before switching to **Pressure Cook** or **Slow Cook** (see **Deglazing**)*

3. Select from the Smart Programs.

## SLOW COOK

Slow Cook lets you make your favorite simmering and stewing recipes, just as you would in a slow cooker. This program does not use pressure to cook food. Make sure the steam release is set to **Vent** or use a glass lid with a venting hole.

Choose from these settings in the Slow Cook Smart Program:

Setting	Less	Normal	More
Best for	'Low and Slow' cooking	Medium setting equivalent on traditional slow cookers	High setting equivalent on traditional slow cookers
Cooking Time	8 hours (08:00)	6 hours (06:00)	4 hours (04:00)

### How to slow cook

#### Prep

Cut, chop, season or marinate your ingredients according to your recipe.

#### Cook

1. Place the **cooking pot** into the **cooker base**.
2. Add ingredients to the **cooking pot**.
3. Place **lid** on top of the **cooker base** and lock the **lid**.
4. Press **Slow Cook**.
5. Cycle through temperature presets to select **Less**, **Normal**, or **More**.
6. Press **- / +** to adjust cooking time.
7. Keep Warm setting is **On** by default. Press **Keep Warm** again to turn it off.
8. After 10 seconds, the display shows **On** and displays timer.

#### Keep Warm

When cooking completes, the display shows **End** if **Keep Warm** is turned off. If not, the timer begins counting from **00:00** up to 10 hours (**10:00**).

## YOGURT MAKING

You can use your Instant Pot Duo to easily make delicious, fermented dairy and non-dairy yogurt.

Choose from these settings in the Yogurt Smart Program:

Setting	Less	Normal	More
<b>Cooking Time</b>	24 hours (24:00)	8 hours* (08:00)	Not adjustable
<b>Best for</b>	For lower temperature fermentation or Jiu Niang, a sweet, fermented rice dessert	Use for fermenting milk	Use for pasteurizing milk

\* You can adjust time from 30 to 99 hours, 30 minutes

### How to make yogurt

#### Pasteurizing Milk

1. Insert **cooking pot** into the **cooker base**.
2. Add unpasteurized milk to the **cooking pot**.
3. Place and close **lid**.
4. Press **Yogurt**.
5. Press **Yogurt** again to cycle through **Less, Normal, More**.
6. After 10 seconds, display shows **boiL**.
7. When pasteurization finishes, display shows **End**.

*Note: Milk must reach a minimum of 161°F / 72°C for pasteurization to occur.*

#### Adding Culture/Starter

1. Allow pasteurized milk to cool to 110°F / 43°C.
2. Add a starter culture to the milk according to package instructions.  
*If using plain yogurt as a starter, ensure that it contains an active culture.  
Mix in 2 tbsp (30 mL) of yogurt per 1 gallon (3.7 L) of milk or follow a trusted recipe.*
3. Place and close **lid**.

## Ferment

1. Press **Yogurt**.
2. Cycle to **Normal** by pressing **Yogurt** again; display shows 8 hours (08:00).
3. Use - / + buttons to adjust the fermentation time if needed.
4. After 10 seconds the cooker begins heating; display shows timer counting up to set time from **00:00**.
5. When fermentation completes, the cooker beeps and display shows **End**.  
*A longer fermentation period will produce tangier yogurt.*
6. Allow yogurt to cool.
7. Place in fridge for 12-24 hours to develop flavors.

## How much to make?

Instant Pot Size	Minimum Milk Volume	Maximum Milk Volume
3 Quarts / 2.8 Liters	2 Cups (16 oz / 500 mL)	2 Quarts (64 oz / 1.9 L)
6 Quarts / 5.7 Liters	4 Cups (32 oz / 1000 mL)	4 Quarts (128 oz / 3.8 L)
8 Quarts / 7.6 Liters	6 Cups (48 oz / 1500 mL)	6 Quarts (192 oz / 5.7 L)

## **KEEP WARM**

The Keep Warm setting turns on automatically after cooking on all Smart Programs except Sauté and Yogurt. You can also use Keep Warm to reheat food.

### **Keep warm after cooking**

1. When automatic warming begins, the timer shows the time passed, up to 10 hours.
2. To turn automatic warming off (either during cooking or during automatic warming), press **Keep Warm** and the light above the button turns off.

### **Reheat and keep warm**

1. When in Standby mode, press **Keep Warm**.
2. Press again to cycle through **Less**, **Normal** and **More** temperature levels.
3. Press the **- / +** buttons to set a timer for up to 10 hours.

## CLEANING

Clean your Instant Pot Duo after each use. Always unplug the unit and let all parts cool to room temperature before cleaning. Before use or storing, make sure all surfaces are dry.

Part	Cleaning instructions
<p>Accessories</p> <ul style="list-style-type: none"><li>• Steam Rack</li><li>• Condensation Collector</li></ul>	<ul style="list-style-type: none"><li>• Wash after each use.</li><li>• Hand wash with hot water and mild dish soap or wash in dishwasher, top rack.</li><li>• Never use harsh chemical detergents, powders or scouring pads on accessories.</li><li>• Empty and rinse condensation collector after each use.</li></ul>
<p>Lid and Parts</p> <ul style="list-style-type: none"><li>• Anti-Block Shield</li><li>• Sealing Ring</li><li>• Steam Release Valve</li><li>• Float Valve</li><li>• Silicone Cap</li></ul>	<ul style="list-style-type: none"><li>• Hand wash with hot water and mild dish soap or wash in dishwasher, top rack.</li><li>• Remove all small parts from lid before washing.</li><li>• With steam release valve and anti-block shield removed, clean interior of steam release pipe to prevent clogging.</li><li>• To drain water from the lid after dishwashing, grasp the lid handle and hold the lid vertically over a sink, then turn it all the way around.</li><li>• After cleaning, store the lid upside down on the cooker base.</li><li>• Store sealing rings in a well-ventilated area to disperse odor.</li><li>• To eliminate odors from sealing ring, add 1 cup (8 oz / 250 mL) water and 1 cup (8 oz / 250 mL) white vinegar to cooking pot, and run Pressure Cook for 5-10 minutes, then use Quick Steam Release.</li></ul>

Part	Cleaning instructions
Cooking Pot	<ul style="list-style-type: none"><li>• Wash after each use.</li><li>• Hand wash with hot water and mild dish soap or wash in dishwasher.</li><li>• Hard water stains may need a vinegar-dampened sponge and scrubbing to remove.</li><li>• For tough or burned food residue, soak in hot water for a few hours before cleaning.</li><li>• Dry all exterior surfaces before placing in cooker base.</li></ul>
Power cord	<ul style="list-style-type: none"><li>• Use a barely-damp cloth to wipe any particles off cord.</li></ul>
Cooker base	<ul style="list-style-type: none"><li>• Wipe the inside of the cooker base as well as the condensation rim with a barely-damp cloth, and allow to air dry.</li><li>• Clean the outside of the cooker base and the control panel with a soft, barely-damp cloth or sponge.</li></ul>

*Some discoloration may occur after machine washing, but this will not affect the cooker's safety or performance.*

## TROUBLESHOOTING

Problem	Cause	Solution
Difficulty closing lid	Sealing ring not properly installed.	Reposition sealing ring, ensure it is snug behind sealing ring rack.
	Contents in cooker are still hot.	Set Steam Release switch to Vent, then lower lid onto cooker base.
Cooking pot is stuck to lid when cooking is complete	Cooling of cooking pot may create suction, causing cooking pot to adhere to the lid.	Carefully lower the cooking pot back into the cooker base and release the vacuum by setting the Steam Release switch to Vent.
Steam leaks from side of lid	No sealing ring in lid.	Install sealing ring.
	Sealing ring damaged or not properly installed.	Replace sealing ring.
	Food debris attached to sealing ring.	Remove sealing ring and clean thoroughly.
	Lid not closed properly.	Open, then close lid.
	Sealing ring rack is warped or off-center.	Remove sealing ring from lid, check sealing ring rack for bends or warps. Contact Consumer Care.
	Cooking pot rim may be misshapen.	If cooking pot is deformed, replace the pot. DO NOT USE. Contact Consumer Care.
Minor steam leaking/hissing from steam release vent during cooking cycle		This is normal; no action required.
Steam gushes from steam release vent when Steam Release switch is in Seal position	Pressure sensor control failure.	Contact Consumer Care.
	Internal Steam Release valve not seated properly.	Move the Steam Release switch quickly to Vent then back to Seal to ensure the Steam Release valve is seated correctly.

<b>Problem</b>	<b>Cause</b>	<b>Solution</b>
Display remains blank after plugging in the power cord	Bad power connection or no power.	Inspect power cord for damage. If damage is noticed, contact Consumer Care.
		Check outlet to ensure it is powered.
Occasional clicking or light cracking sound	Cooker's electrical fuse has blown.	Contact Consumer Care.
	Bottom of the cooking pot is wet.	Wipe exterior surfaces of cooking pot. Ensure heating element is dry before inserting cooking pot into multi-cooker base.
Error code appears on display and multi-cooker beeps continuously	There is an issue with the multi-cooker.	Read "Error Codes" on page 35 for instructions.







## ERROR CODES



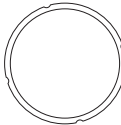

If the control panel shows an error code from this list, there is an issue with the Instant Pot Duo. Here are the actions you should take to fix the problem.

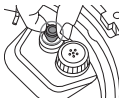
Problem	Cause	Solution
C1 C2 C6	Faulty sensor.	Contact Consumer Care.
C7 or NoPr	Heat element has failed.	Contact Consumer Care.
	Not enough liquid.	Add thin, water-based liquid to the cooking pot.  3 Quarts: 1 cup (8 oz / 250 mL)  6 Quarts: 1 1/2 cups (12 oz / 375 mL)
Lid	Lid is not in the correct position for the selected program.	Open and close the lid.  Do not use a lid when using Sauté.
Food burn	High temperature detected at bottom of cooking pot; multi-cooker automatically reduces temperature to avoid overheating.	Starch deposits at the bottom of the cooking pot may have blocked heat dissipation.  Turn the multi-cooker off, release pressure according to the recipe, and inspect the bottom of the cooking pot.
PrSE	Pressure has accumulated during a non-pressure cooking program.	Set Steam Release switch to Vent.

## REPLACEMENT PARTS

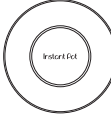
We offer genuine replacement parts for your Instant Pot Duo, if you need them. Visit [www.instantpot.com](http://www.instantpot.com) to order.

	Part	Part number
	Sealing Ring	3QT: 211-0011-01 6QT: 211-0001-01 8QT: 211-0008-01
	SS Cooking Pot (Stainless Steel)	3QT: 212-0001-01 6QT: 212-0401-01 8QT: 212-0601-01
	Ceramic coated AL Cooking Pot (Aluminum)	3QT: 212-0002-01 6QT: 212-0402-01 8QT: 212-0602-01
	Float Valve	3QT: 310-0009-01 6QT: 310-0098-01 8QT: 310-0007-01
	Silicone Float Valve Cap	3QT: 310-0049-01 6QT: 310-0049-01 8QT: n/a
	Steam Release Valve	3QT: 310-0066-01 6QT: 310-0066-01 8QT: 310-0066-01
	Anti-Block Shield	3QT: 310-0006-01 6QT: 310-0006-01 8QT: 310-0006-01

	Part	Part number
	Glass Lid	3QT: 213-0001-01 6QT: 213-0201-01 8QT: 213-0301-01
	Silicone Lid	3QT: 213-0002-01 6QT: 213-0202-01 8QT: 213-0302-01
	Steam Rack - metal	3QT: 210-0002-01 6QT: n/a 8QT: 210-0041-01
	Steam Rack - silicone	3QT: n/a 6QT: 210-0008-01 8QT: n/a
	Condensation Collector Cup	3QT: 310-0003-01 6QT: 310-0001-01 8QT: n/a
	User Manual	3QT: 399-1235-03US 6QT: 399-1235-03US 8QT: 399-1235-03US

In accordance with Québec Regulation O.C. 800-2025, we inform you that we do not sell or provide replacement products to repair this appliance. Certain replacement parts may be available for general maintenance only.

## LEARN MORE

There's a whole world of Instant Pot cooking information and help just waiting for you. Here are some of the most helpful resources.

### Register your product

[Instantpot.com/register](https://Instantpot.com/register)

### Contact Consumer Care

In the Instant Connect™ App

[Instantpot.com/customer-care-center](https://Instantpot.com/customer-care-center)

[support@instantpot.com](mailto:support@instantpot.com)

### Download the Instant Connect™ App

Discover guided cooking and recipes

Available at iOS and Android app stores

### Cooking charts and more recipes

[Instantpot.com](https://Instantpot.com)

### How-to videos, tips and more

[Instantpot.com](https://Instantpot.com)

### Replacement parts and accessories

[Instantpot.com](https://Instantpot.com)

### Join the community



## Product specifications

Model	Volume	Wattage	Power
Duo Mini v5	3 Quarts 2.8 Litres	700 W	120V ~ 60Hz
Duo 60 v5	6 Quarts 5.7 Litres	1000 W	120V ~ 60Hz
Duo 80 v5	8 Quarts 7.6 Litres	1200 W	120V ~ 60Hz

## WARRANTY

### One (1) Year Limited Warranty

This One (1) Year Limited Warranty applies to purchases made one year from the purchase date or delivery date, whichever is later, from authorized retailers of Instant Pot Brands by the original appliance owner and is not transferable. Proof of original purchase date and, if requested by Instant Pot Brands, return of your appliance, is required to obtain service under this Limited Warranty. Provided the appliance was used in accordance with the use & care instructions, Instant Pot Brands will, in its sole and exclusive discretion, either: (i) repair defects in materials or workmanship; or (ii) replace the appliance. In the event that your appliance is replaced, the Limited Warranty on the replacement appliance will expire twelve (12) months from the date of receipt. Failure to register your product will not reduce your warranty rights. The liability of Instant Pot Brands, if any, for any allegedly defective appliance or part will not exceed the purchase price of a comparable replacement appliance.

### What is not covered by this warranty?

- Products purchased, used, or operated outside of the United States and Canada.
- Products that have been modified or attempted to be modified.
- Damage resulting from accident, alteration, misuse, abuse, neglect, unreasonable use, use contrary to the operating instructions, normal wear and tear, commercial use, improper assembly, disassembly, failure to provide reasonable and necessary maintenance, fire, flood, acts of God, or repair by anyone unless directed by an Instant Pot Brands representative.
- Use of unauthorized parts and accessories.
- Incidental and consequential damages.
- The cost of repair or replacement under these excluded circumstances.

EXCEPT AS EXPRESSLY PROVIDED HEREIN AND TO THE EXTENT PERMITTED BY APPLICABLE LAW, INSTANT POT BRANDS MAKES NO WARRANTIES, CONDITIONS OR REPRESENTATIONS, EXPRESS OR IMPLIED, BY STATUTE, USAGE, CUSTOM OF TRADE OR OTHERWISE WITH RESPECT TO THE APPLIANCES OR PARTS COVERED BY THIS WARRANTY, INCLUDING BUT NOT LIMITED TO, WARRANTIES, CONDITIONS, OR REPRESENTATIONS OF WORKMANSHIP, MERCHANTABILITY, MERCHANTABILITY, FITNESS FOR A PARTICULAR PURPOSE OR DURABILITY.

Some states or provinces do not allow for: (1) the exclusion of implied warranties of merchantability or fitness; (2) limitations on how long an implied warranty lasts; and/or (3) the exclusion or limitation of incidental or consequential damages; so these limitations may not apply to you. In these states and provinces, you have only the implied warranties that are expressly required to be provided in accordance with applicable law. The limitations of warranties, liability, and remedies apply to the maximum extent permitted by law. This limited warranty gives you specific legal rights, and you may also have other rights which vary from state to state or province to province.

## Product Registration

Please visit [www.instantpot.com/register](http://www.instantpot.com/register) to register your new Instant Pot Brands appliance. Failure to register your product will not diminish your warranty rights. You will be asked to provide the store name, date of purchase, model number (found on the back of your appliance) and serial number (found on the bottom of your appliance) along with your name and email address. The registration will enable us to keep you up to date with product developments and recipes, and contact you in the unlikely event of a product safety notification. By registering, you acknowledge that you have read and understand the instructions for use, and warnings set forth in the accompanying instructions.

## Warranty Service

To obtain warranty service, please contact our Consumer Care Department by email to [support@instantpot.com](mailto:support@instantpot.com). You can also create a support ticket online at [www.instantpot.com](http://www.instantpot.com). If we are unable to resolve the problem, you may be asked to send your appliance to the Service Department for quality inspection. Instant Pot Brands is not responsible for shipping costs related to warranty service. When returning your appliance, please include your name, mailing address, email address, phone number, and proof of the original purchase date as well as a description of the problem you are encountering with the appliance.



**⚠ WARNING**

**DO NOT** place this appliance on or close to a gas or electric burner, or inside an oven. NEVER use on your stove. Always operate this appliance on a stable, non-combustible, level surface, such as a kitchen countertop.



In Canada, distributed by  
Instant Pot Brands  
199 Bay Street, Suite 4000  
Toronto, ON M5L 1A9 Canada

In U.S., distributed by  
Instant Pot Brands  
8725 W Higgins Road, Suite 725  
Chicago, IL 60631 U.S.

**instantpot.com**

© 2025 Instant Pot Brands  
399-1235-03US

Art release date  
09/30/2025

INSTANT POT  
is a registered trademark  
of Instant Pot Brands

JS 44 (Rev. 10/20) District of Colorado

CIVIL COVER SHEET

The JS 44 civil cover sheet and the information contained herein neither replace nor supplement the filing and service of pleadings or other papers as required by law, except as provided by local rules of court. This form, approved by the Judicial Conference of the United States in September 1974, is required for the use of the Clerk of Court for the purpose of initiating the civil docket sheet. (SEE INSTRUCTIONS ON NEXT PAGE OF THIS FORM.)

I. (a) PLAINTIFFS
CHRISTOPHER GEORGE RECH
(b) County of Residence of First Listed Plaintiff ADAMS, CO
(c) Attorneys (Firm Name, Address, and Telephone Number)
JOHNSON BECKER, PLLC, 444 Cedar Street, Suite 1800, St. Paul, MN 55101; (612) 436-1800

DEFENDANTS
AMAZON.COM, INC.
County of Residence of First Listed Defendant
NOTE: IN LAND CONDEMNATION CASES, USE THE LOCATION OF THE TRACT OF LAND INVOLVED.
Attorneys (If Known)

II. BASIS OF JURISDICTION (Place an "X" in One Box Only)
1 U.S. Government Plaintiff
2 U.S. Government Defendant
3 Federal Question (U.S. Government Not a Party)
4 Diversity (Indicate Citizenship of Parties in Item III)

III. CITIZENSHIP OF PRINCIPAL PARTIES (Place an "X" in One Box for Plaintiff and One Box for Defendant)
PTF DEF
Citizen of This State [X] 1 [ ] 1
Citizen of Another State [ ] 2 [ ] 2
Citizen or Subject of a Foreign Country [ ] 3 [ ] 3

IV. NATURE OF SUIT (Place an "X" in One Box Only)
CONTRACT: 110 Insurance, 120 Marine, 130 Miller Act, 140 Negotiable Instrument, 150 Recovery of Overpayment & Enforcement of Judgment, 151 Medicare Act, 152 Recovery of Defaulted Student Loans (Excludes Veterans), 153 Recovery of Overpayment of Veteran's Benefits, 160 Stockholders' Suits, 190 Other Contract, 195 Contract Product Liability, 196 Franchise.
REAL PROPERTY: 210 Land Condemnation, 220 Foreclosure, 230 Rent Lease & Ejectment, 240 Torts to Land, 245 Tort Product Liability, 290 All Other Real Property.
TORTS: PERSONAL INJURY: 310 Airplane, 315 Airplane Product Liability, 320 Assault, Libel & Slander, 330 Federal Employers' Liability, 340 Marine, 345 Marine Product Liability, 350 Motor Vehicle, 355 Motor Vehicle Product Liability, 360 Other Personal Injury, 362 Personal Injury - Medical Malpractice.
PRISONER PETITIONS: Habeas Corpus: 463 Alien Detainee, 510 Motions to Vacate Sentence, 530 General, 535 Death Penalty. Other: 540 Mandamus & Other, 550 Civil Rights, 555 Prison Condition, 560 Civil Detainee - Conditions of Confinement.
FORFEITURE/PENALTY: 625 Drug Related Seizure of Property 21 USC 881, 690 Other.
LABOR: 710 Fair Labor Standards Act, 720 Labor/Management Relations, 740 Railway Labor Act, 751 Family and Medical Leave Act, 790 Other Labor Litigation, 791 Employee Retirement Income Security Act.
IMMIGRATION: 462 Naturalization Application, 465 Other Immigration Actions.
BANKRUPTCY: 422 Appeal 28 USC 158, 423 Withdrawal 28 USC 157.
PROPERTY RIGHTS: 820 Copyrights, 830 Patent, 835 Patent - Abbreviated New Drug Application, 840 Trademark, 880 Defend Trade Secrets Act of 2016.
SOCIAL SECURITY: 861 HIA (1395f), 862 Black Lung (923), 863 DIWC/DIWW (405(g)), 864 SSID Title XVI, 865 RSI (405(g)).
FEDERAL TAX SUITS: 870 Taxes (U.S. Plaintiff or Defendant), 871 IRS—Third Party 26 USC 7609.
OTHER STATUTES: 375 False Claims Act, 376 Qui Tam (31 USC 3729(a)), 400 State Reapportionment, 410 Antitrust, 430 Banks and Banking, 450 Commerce, 460 Deportation, 470 Racketeer Influenced and Corrupt Organizations, 480 Consumer Credit (15 USC 1681 or 1692), 485 Telephone Consumer Protection Act, 490 Cable/Sat TV, 850 Securities/Commodities/Exchange, 890 Other Statutory Actions, 891 Agricultural Acts, 893 Environmental Matters, 895 Freedom of Information Act, 896 Arbitration, 899 Administrative Procedure Act/Review or Appeal of Agency Decision, 950 Constitutionality of State Statutes.

V. ORIGIN (Place an "X" in One Box Only)
[X] 1 Original Proceeding
[ ] 2 Removed from State Court
[ ] 3 Remanded from Appellate Court
[ ] 4 Reinstated or Reopened
[ ] 5 Transferred from Another District (specify)
[ ] 6 Multidistrict Litigation - Transfer
[ ] 8 Multidistrict Litigation - Direct File

VI. CAUSE OF ACTION
Cite the U.S. Civil Statute under which you are filing (Do not cite jurisdictional statutes unless diversity): 28 U. S. C. 1332
Brief description of cause: Product liability personal injury action involving a defective pressure cooker

VII. REQUESTED IN COMPLAINT:
CHECK IF THIS IS A CLASS ACTION UNDER RULE 23, F.R.Cv.P. DEMAND \$ CHECK YES only if demanded in complaint: JURY DEMAND: [ ] Yes [ ] No

VIII. RELATED CASE(S) IF ANY (See instructions): JUDGE DOCKET NUMBER

DATE: March 20, 2026 SIGNATURE OF ATTORNEY OF RECORD: Adam John Kress

FOR OFFICE USE ONLY
RECEIPT # AMOUNT APPLYING IFP JUDGE MAG. JUDGE

Digitally signed by Adam John Kress Date: 2026.03.20 08:16:0500

## INSTRUCTIONS FOR ATTORNEYS COMPLETING CIVIL COVER SHEET FORM JS 44

### Authority For Civil Cover Sheet

The JS 44 civil cover sheet and the information contained herein neither replaces nor supplements the filings and service of pleading or other papers as required by law, except as provided by local rules of court. This form, approved by the Judicial Conference of the United States in September 1974, is required for the use of the Clerk of Court for the purpose of initiating the civil docket sheet. Consequently, a civil cover sheet is submitted to the Clerk of Court for each civil complaint filed. The attorney filing a case should complete the form as follows:

- I.(a) Plaintiffs-Defendants.** Enter names (last, first, middle initial) of plaintiff and defendant. If the plaintiff or defendant is a government agency, use only the full name or standard abbreviations. If the plaintiff or defendant is an official within a government agency, identify first the agency and then the official, giving both name and title.
- (b) County of Residence.** For each civil case filed, except U.S. plaintiff cases, enter the name of the county where the first listed plaintiff resides at the time of filing. In U.S. plaintiff cases, enter the name of the county in which the first listed defendant resides at the time of filing. (NOTE: In land condemnation cases, the county of residence of the "defendant" is the location of the tract of land involved.)
- (c) Attorneys.** Enter the firm name, address, telephone number, and attorney of record. If there are several attorneys, list them on an attachment, noting in this section "(see attachment)".
- II. Jurisdiction.** The basis of jurisdiction is set forth under Rule 8(a), F.R.Cv.P., which requires that jurisdictions be shown in pleadings. Place an "X" in one of the boxes. If there is more than one basis of jurisdiction, precedence is given in the order shown below.
- United States plaintiff. (1) Jurisdiction based on 28 U.S.C. 1345 and 1348. Suits by agencies and officers of the United States are included here. United States defendant. (2) When the plaintiff is suing the United States, its officers or agencies, place an "X" in this box.
- Federal question. (3) This refers to suits under 28 U.S.C. 1331, where jurisdiction arises under the Constitution of the United States, an amendment to the Constitution, an act of Congress or a treaty of the United States. In cases where the U.S. is a party, the U.S. plaintiff or defendant code takes precedence, and box 1 or 2 should be marked.
- Diversity of citizenship. (4) This refers to suits under 28 U.S.C. 1332, where parties are citizens of different states. When Box 4 is checked, the citizenship of the different parties must be checked. (See Section III below; **NOTE: federal question actions take precedence over diversity cases.**)
- III. Residence (citizenship) of Principal Parties.** This section of the JS 44 is to be completed if diversity of citizenship was indicated above. Mark this section for each principal party.
- IV. Nature of Suit.** Place an "X" in the appropriate box. If there are multiple nature of suit codes associated with the case, pick the nature of suit code that is most applicable. Click here for: [Nature of Suit Code Descriptions](#).
- V. Origin.** Place an "X" in one of the seven boxes.
- Original Proceedings. (1) Cases which originate in the United States district courts.
- Removed from State Court. (2) Proceedings initiated in state courts may be removed to the district courts under Title 28 U.S.C., Section 1441.
- Remanded from Appellate Court. (3) Check this box for cases remanded to the district court for further action. Use the date of remand as the filing date.
- Reinstated or Reopened. (4) Check this box for cases reinstated or reopened in the district court. Use the reopening date as the filing date.
- Transferred from Another District. (5) For cases transferred under Title 28 U.S.C. Section 1404(a). Do not use this for within district transfers or multidistrict litigation transfers.
- Multidistrict Litigation – Transfer. (6) Check this box when a multidistrict case is transferred into the district under authority of Title 28 U.S.C. Section 1407.
- Multidistrict Litigation – Direct File. (8) Check this box when a multidistrict case is filed in the same district as the Master MDL docket.
- PLEASE NOTE THAT THERE IS NOT AN ORIGIN CODE 7.** Origin Code 7 was used for historical records and is no longer relevant due to changes in statute.
- VI. Cause of Action.** Report the civil statute directly related to the cause of action and give a brief description of the cause. **Do not cite jurisdictional statutes unless diversity.** Example: U.S. Civil Statute: 47 USC 553 Brief Description: Unauthorized reception of cable service.
- VII. Requested in Complaint.** Class Action. Place an "X" in this box if you are filing a class action under Rule 23, F.R.Cv.P.
- Demand. In this space enter the actual dollar amount being demanded or indicate other demand, such as a preliminary injunction.
- Jury Demand. Check the appropriate box to indicate whether or not a jury is being demanded.
- VIII. Related Cases.** This section of the JS 44 is used to reference related pending cases, if any. If there are related pending cases, insert the docket numbers and the corresponding judge names for such cases.

**Date and Attorney Signature.** Date and sign the civil cover sheet.



AO 440 (Rev. 06/12) Summons in a Civil Action (Page 2)

Civil Action No. \_\_\_\_\_

**PROOF OF SERVICE**

*(This section should not be filed with the court unless required by Fed. R. Civ. P. 4 (l))*

This summons for *(name of individual and title, if any)* \_\_\_\_\_  
was received by me on *(date)* \_\_\_\_\_ .

I personally served the summons on the individual at *(place)* \_\_\_\_\_  
\_\_\_\_\_ on *(date)* \_\_\_\_\_ ; or

I left the summons at the individual's residence or usual place of abode with *(name)* \_\_\_\_\_  
\_\_\_\_\_, a person of suitable age and discretion who resides there,  
on *(date)* \_\_\_\_\_ , and mailed a copy to the individual's last known address; or

I served the summons on *(name of individual)* \_\_\_\_\_ , who is  
designated by law to accept service of process on behalf of *(name of organization)* \_\_\_\_\_  
\_\_\_\_\_ on *(date)* \_\_\_\_\_ ; or

I returned the summons unexecuted because \_\_\_\_\_ ; or

Other *(specify)*: \_\_\_\_\_

My fees are \$ \_\_\_\_\_ for travel and \$ \_\_\_\_\_ for services, for a total of \$ \_\_\_\_\_ 0.00 .

I declare under penalty of perjury that this information is true.

Date: \_\_\_\_\_

\_\_\_\_\_  
*Server's signature*

\_\_\_\_\_  
*Printed name and title*

\_\_\_\_\_  
*Server's address*

Additional information regarding attempted service, etc: